

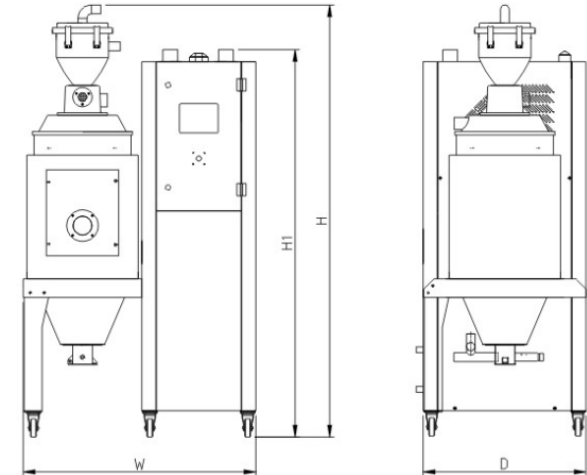

Honeycomb 'All-in-One' Compact Dryer



Model EMD-	25/30	50/50	75/50	100/100	150/100	150/150	200/150	200/200	300/200	300/300	500/300	400/400	500/500	750/500	750/800	1000/800
Drying fan power (kW)	0.4	0.4	0.4	0.75	0.75	1.5	1.5	2.2	2.2	3.4	3.4	4	7.5	7.5	9.0	9.0
Drying heating power (kW)	3	4	4	6	6	7.2	7.2	9	9	15	15	18	21	21	24	24
Fully insulation barrel capacity (L)	40	80	120	150	230	230	300	300	450	450	750	600	750	1200	1200	1500
Regenerative heating power (kW)	3	3	3	3	3	4	4	4	4	6	6	7.2	10	10	12	12
Regenerative fan power (kW)	0.4	0.4	0.4	0.4	0.4	0.4	0.4	0.4	0.4	0.75	0.75	0.75	1.5	1.5	2.2	2.2
Dehumidify air capacity (m3/hr)	30	50	50	100	100	150	150	200	200	300	300	400	500	500	800	800
Feeding fan power (kW)	0.75	0.75	0.75	0.75	0.75	0.75	0.75	1.5	1.5	2.2	2.2	2.2	3.0	3.0	4.0	4.0
ES-* Vacuum hopper (L)	6	7.5	7.5	7.5	7.5	7.5	7.5	12	12	12	12	12	12	12	12	12
ES-* Electronic hopper (L)	3	7.5	7.5	7.5	7.5	7.5	7.5	12	12	12	12	12	12	12	12	12
Suction pipe size (inch)	1.5	1.5	1.5	1.5	1.5	1.5	1.5	1.5	2	2	2	2	2	2	2	2
Dimensions																
H(mm)	1200	1370	2230	2230	2430	2430	2580	2580	2780	3030	3230	3230	3230	3230	3230	3430
H1(mm)	1670	1670	1670	1670	1670	1720	1720	1720	1720	2100	2100	2100	2100	2100	2100	2100
W(mm)	850	1070	1070	1190	1190	1350	1350	1400	1400	1400	1400	1600	1700	1700	1700	1700
D(mm)	620	620	620	820	820	900	900	1000	1000	1200	1200	1300	1300	1300	1300	1300
Weight(kg)	180	300	320	410	430	510	530	560	590	600	650	650	690	690	820	880

Note: We reserve the right of change the specifications without prior notice

- 1) Three sections feeding function is optional, machine type with M3.
- 2) Dew-point meter is optional, machine type with D
- 3) Voltage: 3 ϕ , 400V, 50Hz.