

AIRTECT

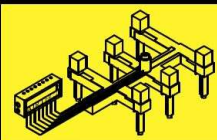

Plastic Leak Alarm System

FOCUS ON PREVENTION

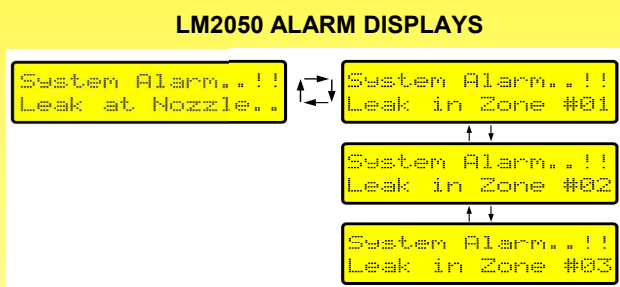
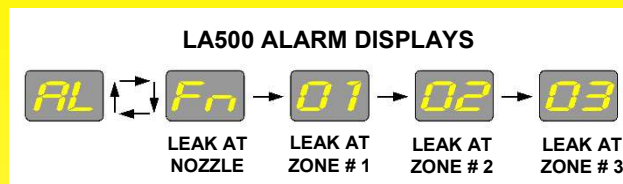
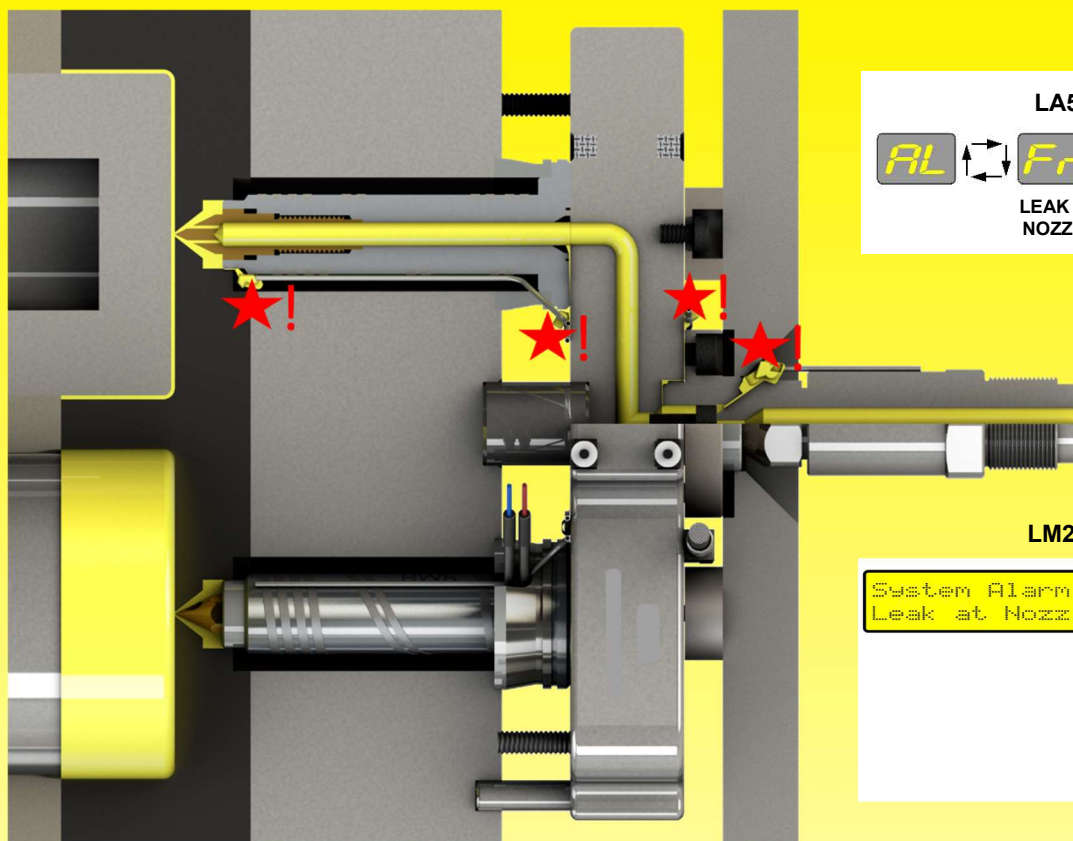
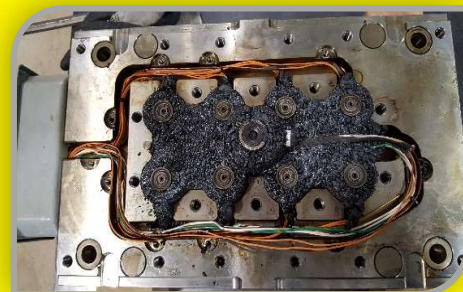

- Reduce the problem of Plastic Leak Damage at the IMM Injection Nozzle or inside a Hot Runner System with an AIRTECT Plastic Leak Detection Solution.
- AIRTECT Plastic Leak Detection Solutions are used worldwide by many companies especially in Automotive, Packaging and Medical Device manufacturing.
- AIRTECT Plastic Leak Detection Solutions are supplied worldwide by a network of distributors.

Plastic Leak Detection Solutions

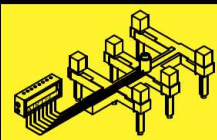

Full range of NOZZLE and HOT RUNNER Leak Detection Modules



NOZZLE AND BARREL PROTECTION

'NOZZLE' LEAK DETECTION MODULES LA500, LA502 and LM2050

Work as Single or Dual (2K) IMM Nozzle Leak Detectors
+ Control/Display/Relay Interlock Modules for
'STANDARD' and 'MODULAR' Leak Detection Manifolds

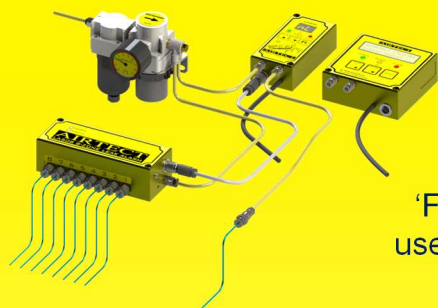

NOZZLE and HOT RUNNER MOULD PROTECTION

'FIXED' and 'MODULAR' LEAK DETECTION MANIFOLDS

'FIXED' and 'MODULAR' Multi-Zone Leak Detection Manifolds are
used with either an LA500, LA502 or LM2050 Control/Display / Relay
Interlock Module

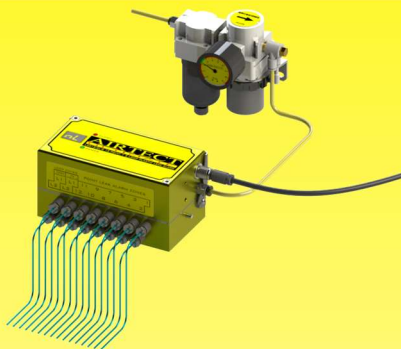

HOT RUNNER MOULD PROTECTION

'FIXED' and 'MODULAR' STAND- ALONE LEAK DETECTION MANIFOLDS

'STAND-ALONE' Multi-Zone Leak Detection Manifolds have an
integral Control/Display / Relay Interlock Module

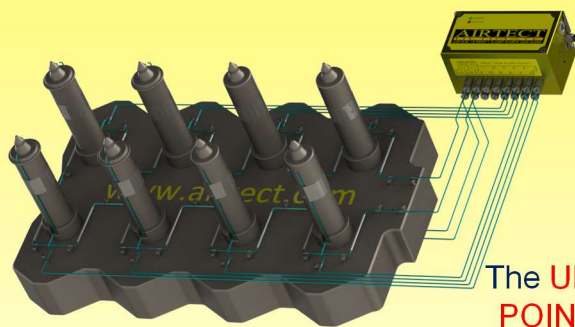

HOT RUNNER MOULD PROTECTION

'ULTIMATE' 'FIXED' and 'MODULAR' STAND-ALONE LEAK DETECTION MANIFOLDS

The **ULTIMATE** range of Leak Detection Manifolds have both
POINT and **CLOSED LOOP** Leak Detection Zones and are
available as 'Stand-Along' units only.

Detect Your NOZZLE and HOT RUNNER Leaks Early!

DESIGNED AND MANUFACTURED BY:

GKET Ltd., E5 Swords Enterprise Park, Feltrim Road,
Swords, Co. Dublin. IRELAND
info@airtect.com www.airtect.com

REPRESENTED BY:

PBE-Roboplas
E: sales@pbe-roboplas.com.au
P: (02) 9674 6511